



## NATIONAL INSTITUTE OF TECHNOLOGY KARNATAKA, SURATHKAL

### DEPARTMENT OF ADMINISTRATION

Address : P.O. Srinivasnagar, Mangalore – 575 025, Karnataka, India  
Phone : +91-824-2474000/24, Fax : +91-824-2474033 Web Site : [www.nitk.ac.in](http://www.nitk.ac.in)

Quotation Notification No.:134/NITK/Asst.Registrar (Academic)/IRG/2019-20/B4

Date: 16/01/2020

### NOTICE INVITING QUOTATION (NIQ)

The National Institute of Technology Karnataka, Surathkal (in short – NITK, Surathkal) established under an Act of Parliament, is an autonomous body under Ministry of HRD Govt. of India, imparting Technical Education and engaged in Research Activities. It is proposed to procure the items for the departmental academic / research activities.

Sealed Quotations as per the Price Schedule given in this NIQ are invited from reputed manufacturers or its authorized dealers for the supply of following items, subject to the terms and conditions enumerate herein, so as to reach on or before scheduled date. The quotations in the firm's Business letter head should be address to the "Director, NITK, Surathkal". The envelope shall be super scribed with the Quotation Notification Number and the Name of the Goods for which quotation is submitted.

<b>Name of Goods</b>	1. Executive Chair 2. Office Table 3. Visitors Chair 4. Computer Table
Period for Supply, after release of Purchase Order:	<b>Immediate</b>
<b>Last date for submission of quotation</b>	<b>24/01/2020 before 3.00 PM</b>
<b>The Estimated Amount</b>	<b>61,000/-</b>

Quotations to be submitted to the following address:

**Superintendent (Purchase)**  
**NITK Surathkal,**  
**P.O. Srinivasnagar – 575 025**

Note : Institute shall not be responsible for any postal delay about non-receipt / non delivery of the bids or due to wrong addressee

### Terms and Conditions

1. The rates should be quoted for FOR destination from supply within India.
2. The agency should possess License certificate for manufacture / supply of the item.
3. The rate quoted should be on unit basis. Taxes and other charges should be explicitly specified therein.
4. **No advance payment will be considered.** Payment will be made only after the supply of the item in good and satisfactory condition.
5. **Guarantee and Warrantee** period should be specified clearly.
6. Period requirement for the supply of item should be specified.
7. In case of dispute, the matter will be subject to Mangalore Jurisdiction only.

**Sd/-**  
**Asst. Registrar A/cs (Purchase)**

**SCHEDULE OF REQUIREMENTS, SPECIFICATIONS AND ALLIED DETAILS**

[To be filled up by the Department / Centre of NITK, Surathkal]

---

Item(s) Name to be Procured and quantity : 1.Executive Chair - 01  
2.Office Table - 01  
3.Visitors Chair - 03  
4.Computer Table - 01

**Brief Specifications of the Item(s) : Annexure I**

Warranty period required : **1 year**

Delivery Schedule expected : **Immediate**  
After placement of Purchase  
Order

**Sd/-**  
**Asst. Registrar A/cs (Purchase)**

## PRICE SCHEDULE

(To be used by the bidder for submission of the quotation)

(Bidder may furnish the same format in the Company letter head)

- 
1. **Item Name** :
  2. Specifications  
(Conforming to Schedule of requirements  
Enclose additional sheets if necessary) :
  3. Currency and Unit Price :
  4. Quantity :
  5. Item Cost (SI NO.3 \* SI. No.4) :
  6. Taxes and Other Charges :
    - (i) Specify the type of taxes and duties in percentages and also in figures.
    - (ii) Specify Other Charges in figures.
  7. **Warranty Period** :  
**(Minimum should conforming to the schedule of requirements)**
  8. Delivery Schedule :
  9. Name and address of the Firm for placing purchase order :
  10. Name and address of Indian authorized agent (in case of imports only) :

**Signature of the Bidder**  
**Seal of the Bidder's Firm**

**Place :**

**Date:**

Sl. No	SPECIFICATION DETAILS	Qty
01	<p><b><u>Office Table</u></b>  Supplying of Side Table made by using Boiling Waterproof marine quality conforming to IS 710 Green /Arched plywood sheets of Phenol bond with 16 mm thick for all the sides, vertical panels, door cabinet sides, drawer and 25 mm thick for table top as shown in the figure. All the external surfaces of the table should be laminated with (Greenlam / sunmica) of approved colour, 1 mm thick and 0.8 mm thick for all internal sides. The exposed edges of the table should be finished with 2mm thick PVC edge banding of approved make quality &amp; colour. The lamination &amp; edge banding work should be done in Mechanical means with Automatic Roll, pneumatic press, heat and fix with approved adhesive for lamination &amp; Automatic Gluing, Pneumatic pressure press, fine milling the edges, corner rounding, scrapping &amp; buffing for finishing the edges of PVC edge banding. All the fixtures and fittings like hinges with screws for cabinet door shutter, SS Handle with locking arrangements, fiber bush, etc. should be provided of approved quality and make.  Size: 1.83 M (L) x 0.91M (W) x 0.75 M (H)</p>	01
02	<p><b><u>Executive Chair</u></b>  Supplying Executive chairs, revolving &amp; tilting type PU (polyurethane) arms and mesh back, Gas lift height adjustment, Push back mechanism, Tension control tilt lock mechanism, 90-degree tilt lock, High quality imported wheels, Featherlite/Damro/Godrej contact project high back chair.</p>	01
03	<p><b><u>Wooden Chair</u></b>  Supplying of Wooden chair with cushion seat and backrest made by using mahogany wood of size 50mm x 30mm size for vertical, horizontal supports, 25mm x 65mm size for cushion supports. 20mm x 45mm size for back supports and leg supports. All the wooden sizes are finished thickness. All the internal and external surfaces of wood should be treated with sanding sealer mixed with thinner, after rubbing with zero size sand paper and applying sealer coat by way of spraying with necessary compressor and after rubbing with steel wool, applying two coats of approved shade of melamine Interior grade matt finish to provide anti-scratch and anti-stain properties (second coat of polish to be applied after drying of first coat) of approved make and approved colour to give good finish as per the specification. The seat and backrest should be covered with 50 mm thick 32 density moulded rubber with fabric cover, with 10mm thick marine ply-wood for seat and 6 mm thick marine ply-wood for back-supports. The work should be completed as per the detailed drawing and directions of the work in charge.  Size: 0.55 M (L) x 0.55M (W) x 0.90M (H)</p>	03
04	<p><b><u>Computer Table</u></b>  Supplying of Computer table made by using Boiling Waterproof marine quality conforming to IS 710 Green /Arched plywood sheets of Phenol bond with 16 mm thick for all external sides - door cabinet sides, drawer and sliding keyboard, and 25 mm thick for table top, as shown in the figure. All the external surfaces of the computer table should be laminated with (Greenlam / sunmica) of approved colour, 1 mm thick and 0.8 mm thick for all internal sides. Exposed edges of the table should be finished with 2mm thick PVC edge banding of approved make quality &amp; colour. The lamination &amp; edge banding work should be done in Mechanical means with Automatic Roll, pneumatic press, heat and fix with approved adhesive for lamination &amp; Automatic Gluing, Pneumatic pressure press, fine milling the edges, corner rounding, scrapping&amp; buffing for finishing the edges of PVC edge banding. All the fixtures and fittings like hinges with screws for cabinet door shutter, SS Handle with locking arrangements, fiber bush, etc. should be provided of approved quality and make.  Size: 1.22 M (L) x 0.60 M (W) x 0.75 M (H)</p>	01

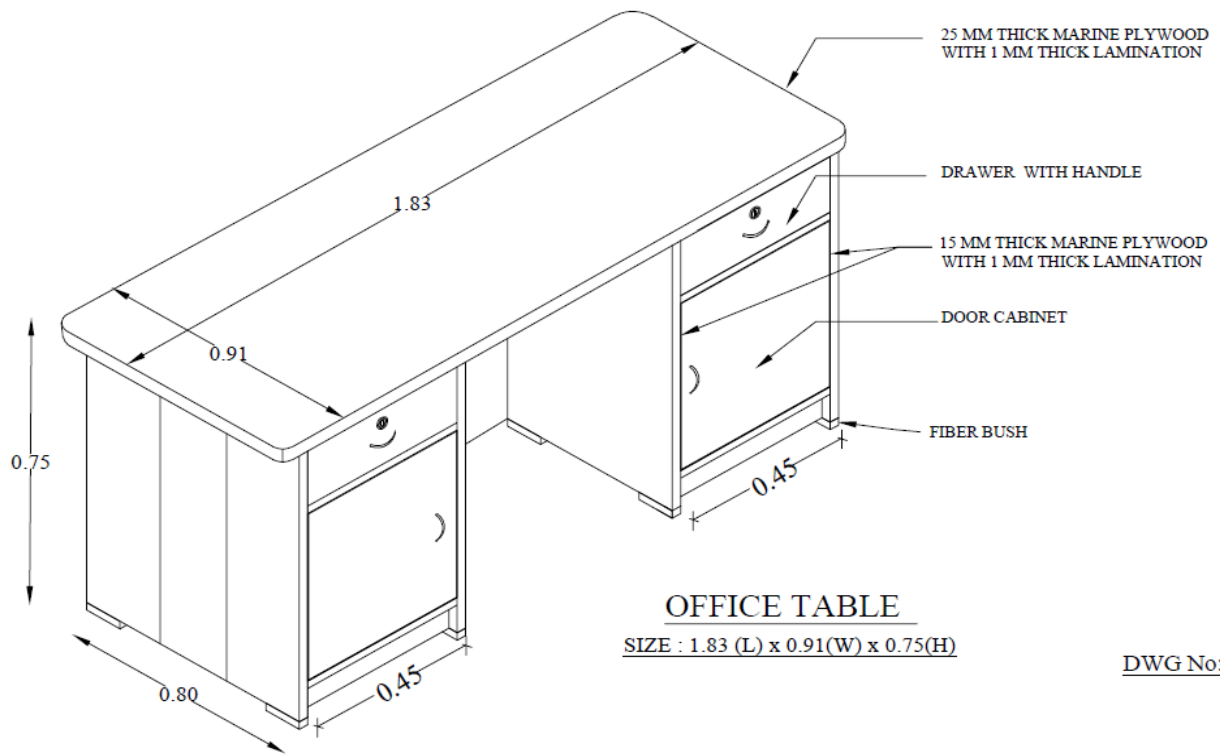

**EXECUTIVE CHAIR**

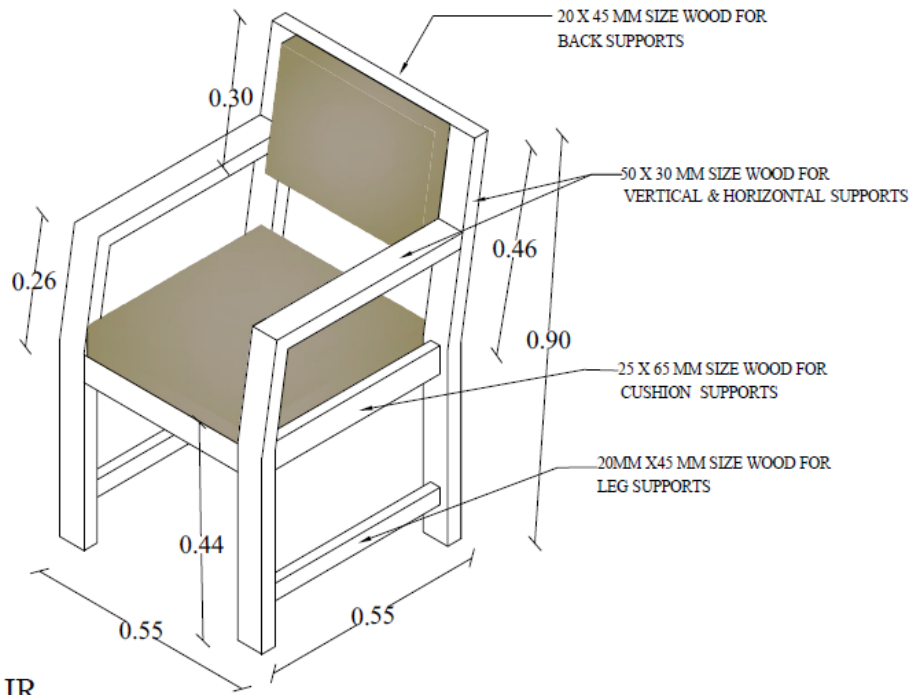

**WOODEN CHAIR**

( SIZE : 0.55(L) X 0.55(W) X 0.90(H) )

DWG No:

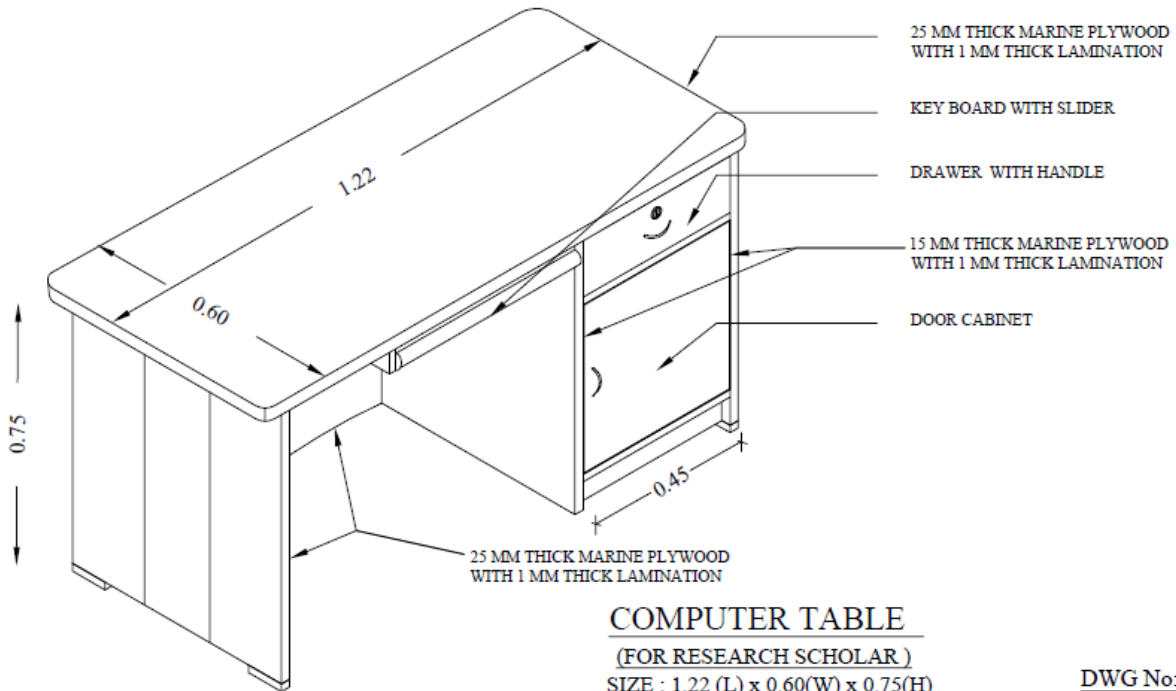

**COMPUTER TABLE**

(FOR RESEARCH SCHOLAR)

SIZE : 1.22 (L) x 0.60(W) x 0.75(H)

DWG No: 1